

Fanlight Front

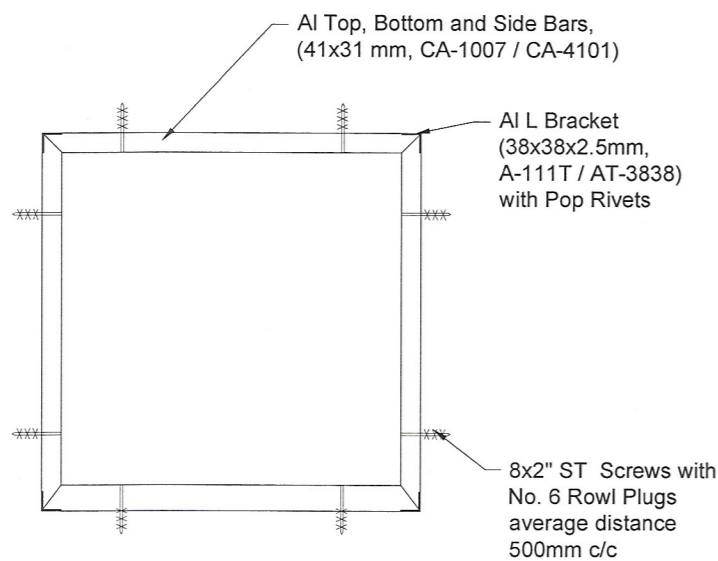

Fanlight Frame

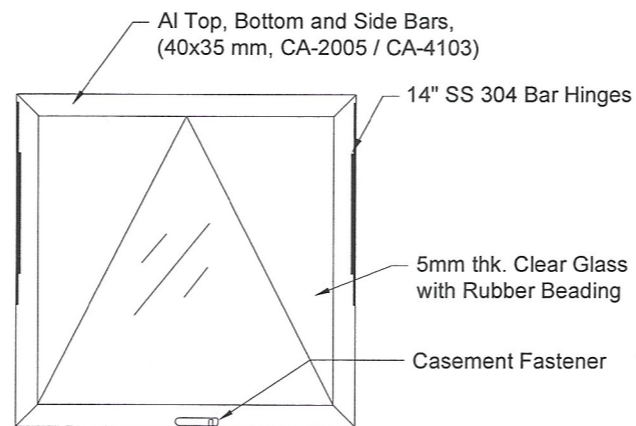

Fanlight Sash

NOTES -

1. One aluminium section brand should be used for the entire project.
2. Approved aluminium sections brands are Alumex and Swisstec. Other accessories should be get approved from the Engineer.
3. Fabrication works should be done at the site. Otherwise the Contractor is responsible to show the quality of the work.
4. Aluminium section bars joining are not allowed. If required need to get prior approval from the Engineer.
5. Sizes of the work may be changed according to the project. Need to get prior approval from the Engineer before starting works.

600x600 mm FAN LIGHT

(SPES/RATE23/FL/01)

No any alteration is allowed without due permission of DCS(Eng). Any unauthorized alteration is subjected to have disciplinary action. Re-production is not permitted.
DCS(Eng)

**DETAILED DRAWING
(RATE ANALYSIS)**

All right reserved. This work or any part of thereof should not be reproduced without written permission of the Engineering Services Office of Southern Provincial Council.

Sheet No : 01	Checked By : (K.L.K.S. Gunawardhana)
Drawing No : SPES/RATE23/FL/01	Checked By : (W.A. Sarath Kumara)
Scale : 1 - 12	Engineer Assistant : (H.T. Liyanagama)
Date : 2023-08-01	Engineer : (Eng. D.D.S. Edirisooriya)
Drawn By : (Thilini Meththananda)	Director (Engineering) : (Eng. C.B. Abayadeera)

ENGINEERING SERVICES OFFICE.
SOUTHERN PROVINCIAL COUNCIL, GALLE.

Tel- 0912242786 / 0912246151 / 0912233125 / 0912242785 / 0914941541 / 091224837
FAX- 0912242786 E-mail - gaks@sltel.lk / info-eng@cs.spgov.lk / designbranchgalle@gmail.com